

Aqua

The Temperature
Control People.

Adiabatic Cooling Solutions

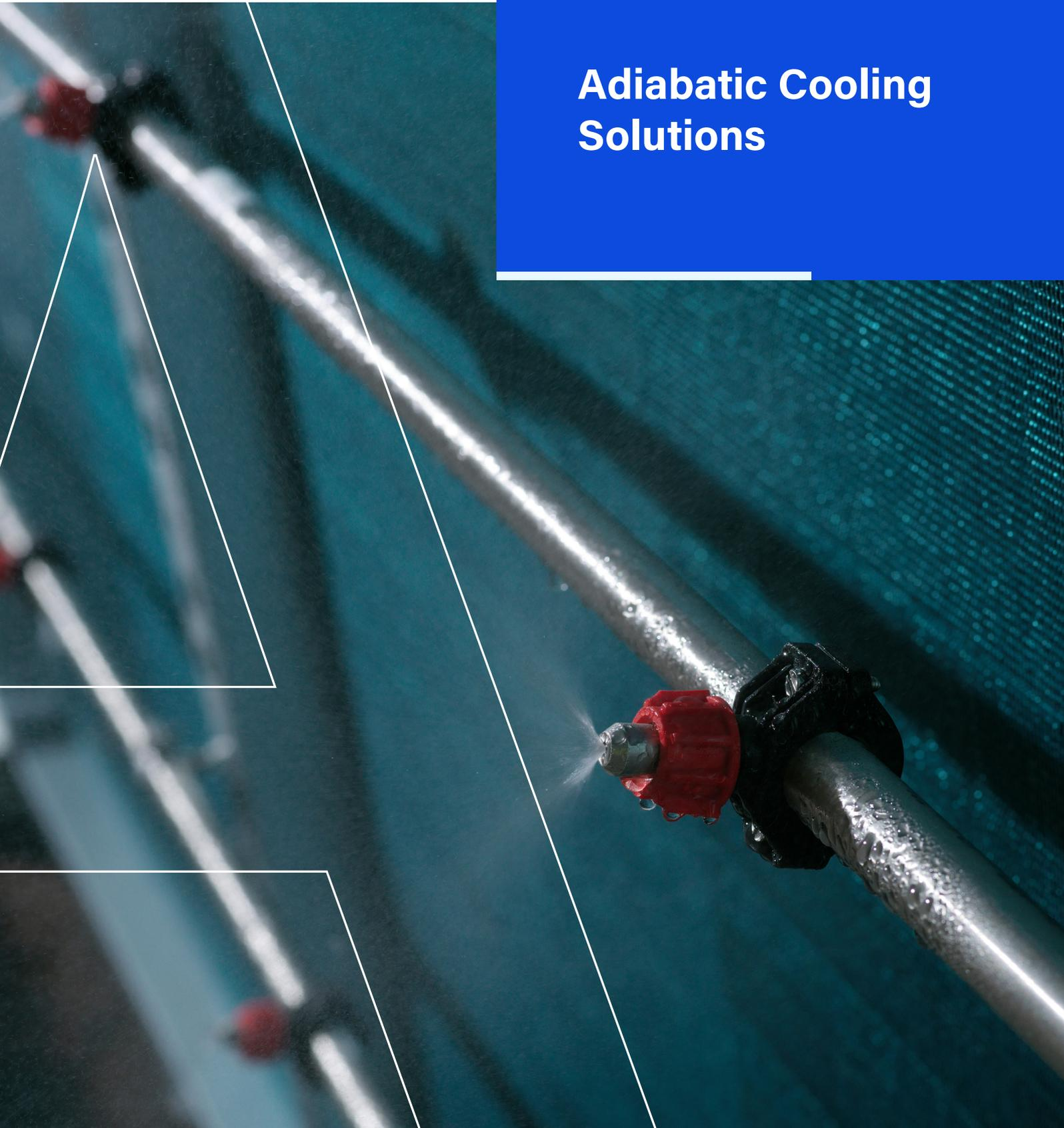

Why Choose Adiabatic Cooling?

Put simply, our adiabatic cooling solutions only use water when absolutely necessary, meaning they are ultra-efficient, keeping your business's operating costs to a minimum.

With environmental impact of water use and energy consumption being such important considerations within our industry, adiabatic cooling is an ideal solution to the demands of modern-day heat rejection systems.

The technology is suited to a number of applications, including process cooling, compressed air, data centres, refrigeration, engine cooling, CHP, cooling tower replacement and food & pharmaceutical manufacture.

What Makes Our System Different?

Our system doesn't operate on fixed ambient air temperature, rather it works by achieving the perfect balance between load, ambient water use and fan speed.

This includes:



Innovative control management system that engages the water spray only when all possible dry operation has been exhausted. Even then, it ensures maximum water evaporation and minimal wastewater. This keeps the coil clear (eliminating the risk of salt build up) and protects system longevity. Heat extraction and dissipation is achieved with optimal efficiency - in both electrical and water usage categories.



Unique DC motor-driven, 4-10 bar spray pump delivers exactly the right amount of water spray, as and when required



EC Fans keep noise levels and electrical usage at an absolute minimum. In addition, these give the units built-in resilience. Each fan has an AC/DC converter and speed control delivered via a signal from the controller. Should the signal be lost, the fans automatically go to a pre-set speed level to ensure that your facility is kept running 24/7.



The Savings

The Aqua adiabatic system uses just a fraction of the amount of water used by a cooling tower installation. Let's take this example selection and compare the cost savings:

Example: 500kW cooling with fluid onto the adiabatic cooler or cooling tower at 40°C, off at 30°C and in a dry bulb of 32°C and wet bulb of 19°C.

Cooling Tower Solution		Aqua Adiabatic Solution
1,352 m ³ /year	 Water	35 m ³ /year
1,603 kW hrs/year	 Electricity	13,358 kW hrs/year
£22,864	 Running Cost***	£1,405

* Including bleed
 ** Based on an inverter-driven fan option
 *** Based on 10p/kW hr for electricity and £2/m³ for water

Whilst the electrical load is higher for an adiabatic solution, the reduction in water more than makes up for it. In fact, the savings are even greater as a cooling tower requires mains water and this process itself demands electricity. If we look at the holistic CO2 footprint and taking into account the water utilities electric usage to purify and supply the water this only adds to the significant difference between the two options.

Savings:
£21,459 (per annum)

Additional savings on water/chemical treatment approx. :
£20,000 (per annum)

How It Works

Put simply, our adiabatic cooling solutions only use water when absolutely necessary, meaning they are ultra-efficient, keeping within the UK, during winter, spring and autumn (and even on cooler summer days and nights) our adiabatic cooler works in the same way as a typical air blast cooler. But, when the ambient temperature goes above the required dry bulb and all the fans are at full speed, the adiabatic spray is activated. However, if the fans are not at full speed due to a reduced cooling load the intelligent controller will not activate the spray as the coil can continue to operate dry until a higher temperature.

Initially, the spray starts at a 4-bar pressure but as the ambient increases the adiabatic pump increases its speed to increase the pressure at the nozzles to 10-bar, ensuring just the right amount of water spray is used to achieve the reduced air temperature. Traditional adiabatic coolers utilise an on/off spray system by either starting or stopping the pump or bypassing water around the pump to stop the spray - this achieves inconsistent air temperatures and wastes water.

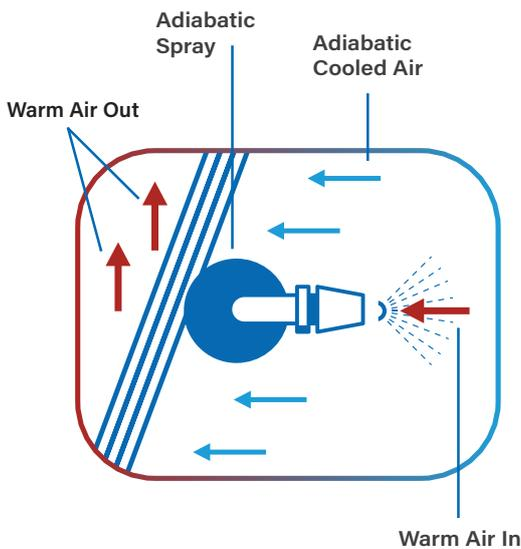

The graph below depicts the fan kW and water usage compared to ambient temperature.

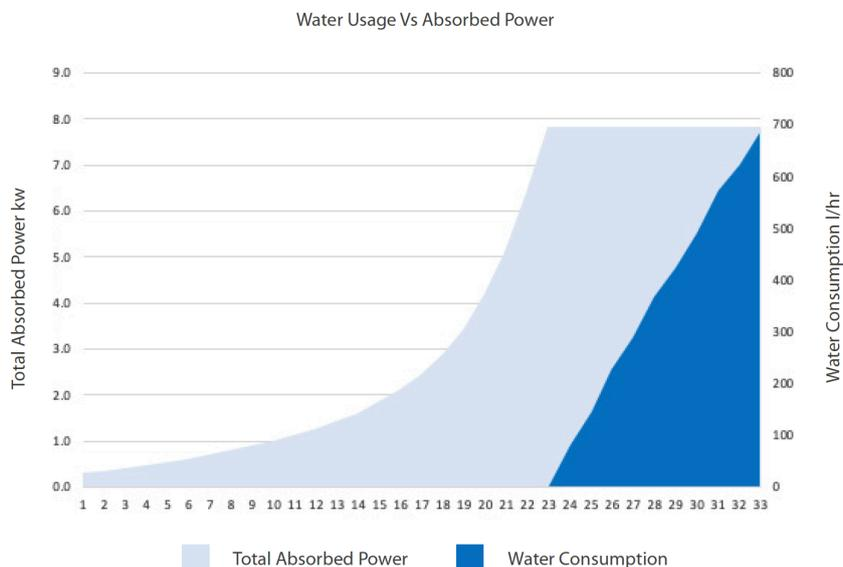

All About Quality



1

Industrial UV on mains water inlet ensures a bug free spray system. Hour usage AND failure alarms with added Wi-Fi connectivity to notify the user.

2

High-capacity 50-micron water filter preserves quality of water entering the spray system and giving maintenance-free running and a reduced risk of nozzle blocking.

3

DC-driven variable speed 4-10 bar pump. Speed is regulated by the main temperature controller, ensuring water usage is minimised and outlet fluid temperatures from the cooler are accurately maintained.

We use actuated valves for repeat reliability after long periods of no use and to eliminate water hammer.

After every use, the complete adiabatic mains water system empties to ensure a dry system to help eliminate bacterial growth.

All wetted parts are non-ferrous and pipework is 304L stainless throughout.



All coils are coated with a hydrophilic coating to ensure that water logging or evaporation of water off the surface is minimised to keep the coils free of contamination and scale.

All nozzles are carefully selected for each model to ensure the correct amount of flow and pressure resistance is delivered.

Each nozzle can be removed by the twist of the casing and then each stainless nozzle can be removed, disassembled, cleaned and replaced within minutes.

Stainless steel piping ensures longevity of life and a unit that looks as good in years as it did on day one.

EC Fans

All fans are IE4 efficiency and therefore ahead of legal requirements. Ultra-low noise emissions compared to that of AC fans with inverters, and due to the design of the EC configuration, it allows for continuous adjustment of air flow for maximum performance and control.



Operation

As well as the standard V bank configuration we also can supply flatbed in the standard configuration, blow through for high temperature configuration and vertical if required. Units can also be supplied with extended legs for space saving or restricted air flow installations.

Flatbed



Extended leg version



Pump Sets

At Aqua, we have the facility to design and manufacture pump sets and pump & tank sets to complement our range of adiabatic coolers. These can be designed in open or closed formations, depending on whether the system is pressurised or not. They can also be arranged as single pump, dual pump (for run and standby arrangements) or even triple pump (for 2 run and 1 standby).

As standard, our pump sets come with folded, galvanised steel, painted frames and 304l thin walled stainless steel pipework. They can also be produced with a fully stainless steel frame and pipework for ultra-pure water systems or with ABS Class E pipework, if required. Pumps range from 1.5 to 10 bar pressure and are either N suction, multi-stage or magnetic driven, dependent on application. The pump sets have either stand-alone inverters or full pre-wired control panels with Star Delta, soft start or inverter driven options.

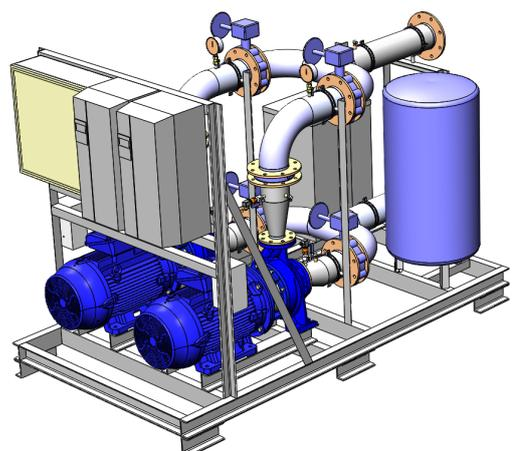
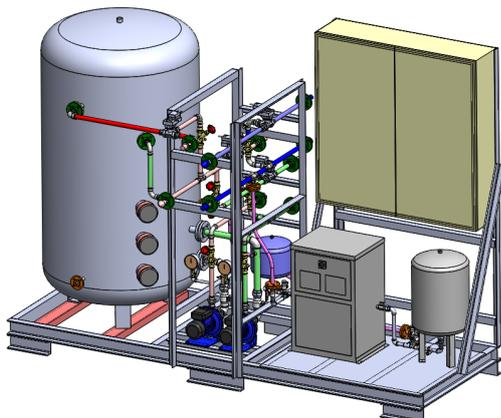
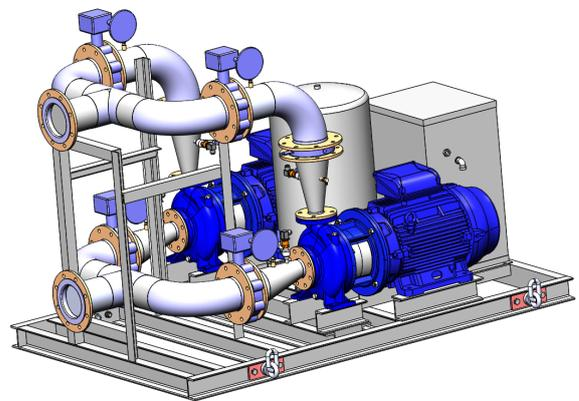
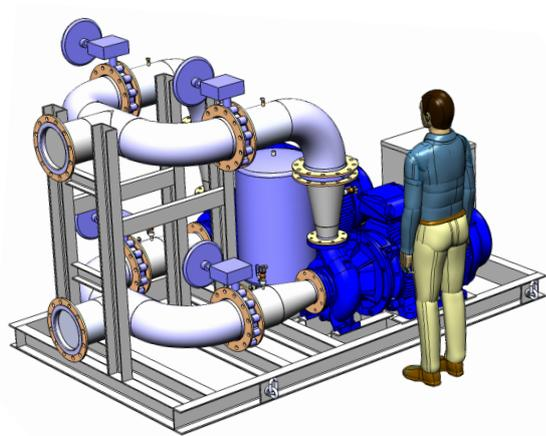

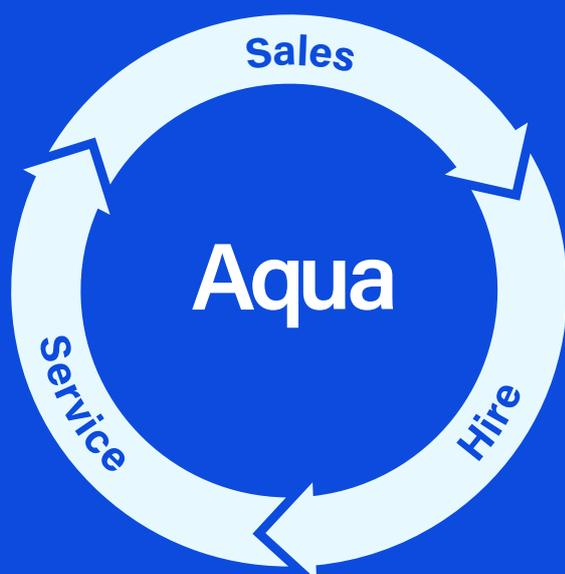

Sales, Hire, Service. Nationwide Coverage, Local Presence.

Aqua are temperature control specialists, committed to designing & delivering market-leading solutions with a focus on energy efficiency, technical excellence and great customer service. Our Sales, Hire & Service divisions work together to offer a 360° approach.

With Engineers located across the UK, we deliver a local service with all the benefits you'd expect from a national company. Our Service Engineers are all F-Gas registered and Aqua are ISO 9001 and SafeContractor accredited.

Whether you're looking to purchase equipment, hire on a short or longer term basis, or needing support with service, maintenance & parts, we can help.

Contact us today and discover the Aqua Difference.



0333 004 4433



aquacooling.co.uk



sales@aquacooling.co.uk

